

# PH SD Card Datalogger

## SP-850060/61

### Instruction Manual



1295 Morningside Ave., Unit 16-18  
Scarborough, ON. M1B 4Z4 Canada  
Phone: 416-261-4865 Fax: 416-261-7879

---

Environmental Measurement Instruments

PH SD Card Datalogger SP-850060  
Copyright ©2010 by Sper Scientific  
ALL RIGHTS RESERVED  
Printed in the USA

The contents of this manual may not be reproduced or transmitted in any form or by any means electronic, mechanical, or other means that do not yet exist or may be developed, including photocopying, recording, or any information storage and retrieval system without the express permission from Sper Scientific.

## TABLE OF CONTENTS

INTRODUCTION . . .	5
FEATURES . . .	.5
MATERIALS SUPPLIED . . .	.5
POWER SUPPLY . . .	.6
METER COMPONENTS . . .	.6
KEYPAD . . .	.7
SETUP . . .	..8
CALIBRATION . . .	..12
MEASUREMENT PROCEDURES . . .	15
DATALOGGER . . .	20
BATTERY REPLACEMENT . . .	23
MAINTENANCE . . .	24
TROUBLESHOOTING . . .	26
OPTIONAL ACCESSORIES . . .	27
SPECIFICATIONS . . .	32
WARRANTY . . .	36

## **INTRODUCTION**

The Sper Scientific PH SD Card Datalogger (Model SP-850060) is an intelligent meter that reads pH and mV.

This meter has a wide variety of applications in industries such as water conditioning, aquariums, fish hatcheries, food processing, photography, laboratory, paper, plating, quality control, and science education.

This meter features a real time SD memory card datalogger. Standard, portable SD memory cards provide unlimited data storage and upload pre-formatted data directly to Excel, eliminating the need for cables or software. Each data set includes pH or mV measurement, time and date.

## **FEATURES**

- Reads pH and mV
- Automatic or manual temperature compensation for pH measurement
- SD memory card datalogger
- Manual datalogger option
- Highly accurate microcomputer circuit
- Direct upload of data to Excel
- Internal clock and calendar
- Touch-tone
- Tripod mounting screw
- Built-in tabletop stand
- Maximum and minimum
- Hold function
- Auto-power-off
- Low battery indicator
- Backlight

## **MATERIALS SUPPLIED**

- Meter
- SD Card
- 6 AA Batteries
- Instruction Manual
- Soft Carrying Case

## POWER SUPPLY

This meter can be powered by six AA (1.5 V, UM3) batteries or an optional 9 Volt DC adapter. See page 23 for battery replacement instructions.

Plug the adaptor into the power port labeled “DC 9V,” located on the side of the meter (under the protective black cover).

### Note...

When using the adapter, the meter will remain permanently on and the POWER button will be disabled.

## METER COMPONENTS

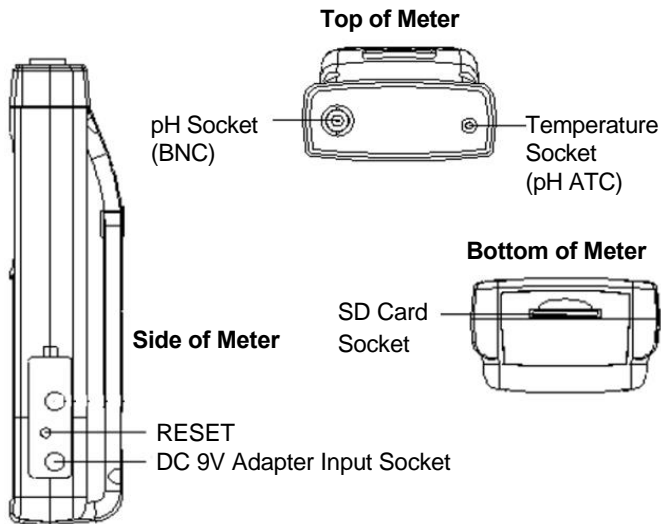

## Back of Meter

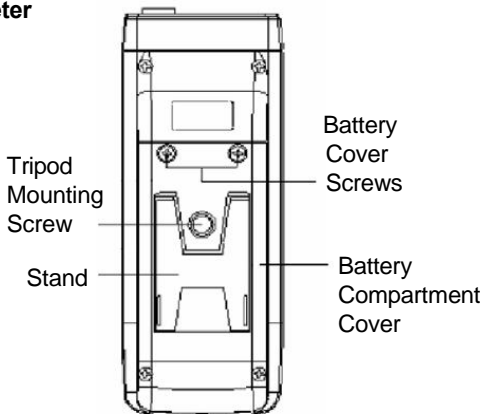

## KEYPAD

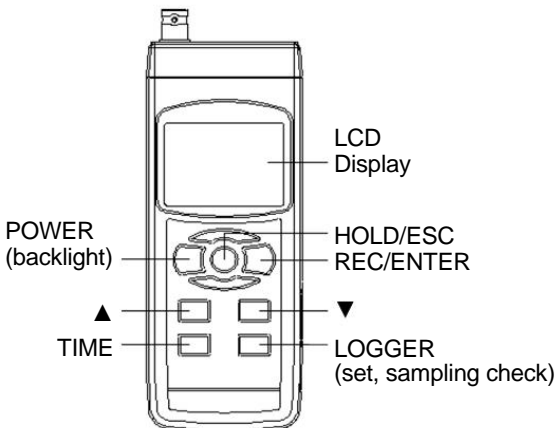

## SETUP MODE

The advanced Setup Mode allows you to customize the following meter preferences and defaults:

- SD Memory Card Format
- Real Time Clock
- Sampling Time
- Auto Power Off
- Touch-Tone
- Decimal Type
- Temperature Units
- Manual Temperature Compensation Value

### **Note...**

The setup functions can be performed under any parameter but not while utilizing the datalogger function. Once selections are saved, the meter will default to the selected preferences.

1. Press **POWER** to turn the meter on.
2. Press **SET** for 2 seconds or longer to enter Setup Mode.
3. Press **SET** to cycle through the setup functions.

### **Note...**

Press **ESC** to exit Setup Mode. The meter will return to Normal Mode.



## SD Memory Card Format

Enabling this function will format the SD memory card to work specifically with your meter. Formatting the SD card will erase any previous memory on the card. New SD cards should be formatted to work with your meter.

1. Enter the SD memory card format function from Setup Mode (see page 8). “Sd F” appears on the LCD.
2. Press ▲ or ▼ to select yes (format the SD memory card) or no (do not format the SD memory card). Press **ENTER** to confirm your selection. If selecting yes, “yES Enter” will appear on the LCD, press **ENTER** again and the meter will format the SD card.

## Real Time Clock

1. Enter the clock function from Setup Mode (see page 8). “dAtE” appears on the LCD.
2. Press **ENTER**. The year will flash on the LCD.
3. Press ▲ or ▼ to adjust the value. Press **ENTER** to save the value.
4. Repeat Step 3 to adjust the month, date, hour, minute and second.
5. Press **SET** to complete the clock setup function.

### Note...

This procedure adjusts the meter’s internal clock. The internal clock will function when the meter is turned off but only when the batteries have adequate power (not with low battery power.)

## Sampling Time

The sampling time (hour/minute/second) is the time allotted between successive measurements. To adjust the sampling time:

1. Enter the sampling time function from Setup Mode (see page 8). “SP-t” appears on the LCD.
2. Press ▲ or ▼ to adjust the value (starting with the hour value). Press ENTER to save the value. The meter will advance to the next value adjustment (minute, second).
3. Repeat Step 2 until the setting is complete.
4. Press **SET** to save the value.

## Auto Power Off

The meter automatically turns off after 10 minutes of inactivity, however this function can be disabled.

1. Enter the auto power off function from Setup Mode (see page 8). “PoFF” appears on the LCD.
2. Press ▲ or ▼ to select yes (auto power off enabled) or no (auto power off disabled). Press ENTER to save the selection.

## Touch-Tone

1. Enter the touch-tone function from Setup Mode (see page 8). “bEEP” appears on the LCD.
2. Press ▲ or ▼ to select yes (touch-tone enabled) or no (touch-tone disabled). Press **ENTER** to save the selection.

## Decimal Type

Although the decimal is commonly expressed as the “.” symbol (i.e., 20.6 or 1000.53), some (European) countries use a “,” symbol to represent the decimal (i.e., 20,6 or 1000,53). The meter defaults to the period symbol. To adjust:

1. Enter the decimal type function from Setup Mode (see page 8). “dEC” appears on the LCD.
2. Press ▲ or ▼ to select Basic (.) or Euro (,). Press **ENTER** to save the selection.

## Temperature Units

1. Enter the temperature units function from Setup Mode (see page 8). “t-CF” appears on the LCD.
2. Press ▲ or ▼ to select C (degrees Celcius) or F (degrees Fahrenheit). Press **ENTER** to save the selection.

## Manual Temperature Compensation Value (pH only)

1. Enter the manual temperature compensation function from Setup Mode (see page 8). “t-SET” appears on the LCD.
2. Press ▲ or ▼ to adjust the value to the desired selection (in °C or °F). Press **ENTER** to save the selection.

### Note...

After completing this function, press **SET** to advance to the next function. “ESC” appears on the LCD. Press **ESC** to complete the setup procedures and return to Normal Mode.

## CALIBRATION

This meter has been calibrated using a pH probe with an ideal reading: generates 0 mV at pH 7.00 (177.4 mV at pH 4) in an ambient temperature of 25°C. Because your probe may not be ideal, calibration is necessary before first time use. For best results, calibrate your meter weekly. For the highest accuracy, we recommend a two point calibration. Begin with pH 7 (then calibrate pH 4 or 10).

To calibrate:

1. Prepare the probe for calibration (see page 12).
2. Using a standard pH and/or ATC probe, plug the probe plug into the pH probe socket.
3. Press **POWER** to turn the meter on.
4. For the standard pH probe only (not ATC): Adjust the manual temperature compensation value to the same value as the solution temperature. (See page 11).
5. Select the pH buffer and pour solution (a sufficient amount to totally immerse the probe tip) into a clean container.
6. Dip the probe into the container, immersing the probe tip. Gently shake the probe.

### **Note...**

If calibrating the ATC probe with the pH probe, dip the probes in the solution simultaneously.

7. The pH value appears on the LCD.

8. Press **REC** and **HOLD** simultaneously until "PH" appears on the display.

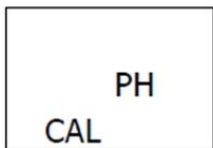

9. Press ▲ or ▼ in sequence to select the following screens:

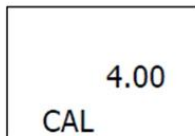

pH 4.0  
calibration

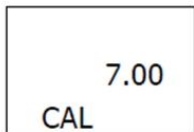

pH 7.0  
calibration

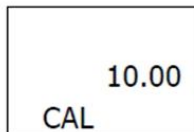

pH 10.0  
calibration

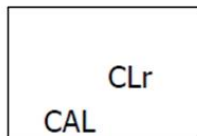

Clear the existing  
calibration data

10. When the desired screen is reached (pH 7 for the first calibration point), press **ENTER** to save the calibration data and complete the procedure.

**Note...**

To clear the existing calibration data, press **ENTER** when the "CLr" screen appears on the LCD.

11. Repeat the calibration procedure for pH 4 or pH 10, using the corresponding buffer solution.
12. Repeat the entire procedure for the two calibration points at least twice.

## MEASUREMENT PROCEDURES

### Turning the Unit On/Off

1. Press **POWER** to turn the meter **on**.
2. Press and hold **POWER** for 2 seconds to turn the meter **off**.

### Selecting the Function

Press and hold **FUNC** to cycle through the options listed below. Release **FUNC** when you reach the desired function.

- pH  
“pH” appears on the LCD.
- mV  
“mV” appears on the LCD

### Defaults

The meter will default to the following settings:

- pH
- °C
- Manual ATC (without connecting the ATC probe)
- Auto power off
- Datalogger sampling time: 2 seconds

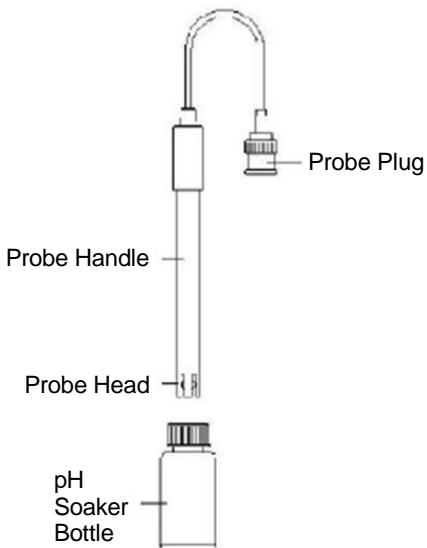

## Preparing the pH/ORP Probe

1. Remove the pH or ORP probe soaker bottle by rotating the bottle and cap and slide the bottle and cap off the probe.
2. Rinse the probe tip with de-ionized or distilled water before use.

### Note...

If the probe tip is dehydrated, soak it for 30 minutes in a KCl solution. **DO NOT** wipe the pH probe dry. Wiping the probe may cause static and cause measurement instability.



## **pH Measurement with Manual Temperature Compensation**

1. Press **POWER** to turn the meter on.
2. Using a pH probe, plug the probe plug into the pH probe socket.
3. Adjust the manual temperature compensation value to the same value as the solution temperature. (See page 11).
4. Select the pH buffer and pour solution (a sufficient amount to totally immerse the probe tip) into a clean container.
5. Dip the probe into the container, immersing the probe tip. Gently shake the probe.
6. The pH value appears on the upper display of the LCD. The manual temperature compensation value appears on the lower display.

## **pH Measurement with Automatic Temperature Compensation (ATC)**

This meter is designed to take readings with automatic or manual temperature compensation. Automatic temperature compensation only occurs when a temperature probe is plugged into the meter.

1. Press **POWER** to turn the meter on.
2. Using a pH probe, plug the probe plug into the pH probe socket.
3. Using a temperature (ATC) probe, plug the probe plug into the temperature probe socket.
4. Select the pH buffer and pour solution (a sufficient amount to totally immerse the probe tip) into a clean container.

5. Dip both probes into the container, immersing the probe tips. Gently shake the probes.
6. The pH value appears on the upper display of the LCD. The solution's temperature value (measured by the ATC probe) appears on the lower display.

### **mV Measurement**

This meter has a built-in mV (millivolt) measurement function, which allows for ion-selective, ORP (oxidation-reduction potential) and other precise mV measurements.

1. Press **POWER** to turn the meter **on**.
2. Press **FUNCTION**. "mV" appears on the LCD.
3. Using an ORP probe, plug the probe plug into the pH probe socket.
4. The mV value appears on the LCD.

### **Hold Function**

1. Press **HOLD** to freeze the reading on the display. "HOLD" will appear on the LCD.
2. Press **HOLD** again to release the hold function. "HOLD" will disappear from the LCD.

### **Maximum and Minimum**

To record maximum and minimum readings:

1. Press **REC** to begin recording the maximum and minimum values. "REC" appears on the LCD.

2. Press **REC**. The maximum value and “REC MAX” will appear on the LCD.
3. Press **REC**. The minimum value and “REC MIN” will appear on the LCD.
4. To delete the maximum or minimum value, press **HOLD**. “REC” appears on the LCD and the meter will begin recording the maximum and minimum values again.
5. To exit the min/max function, press and hold **REC** for 2 seconds. The meter will return to Normal Mode.

### **Backlight**

1. The backlight turns on automatically when the meter is turned on.
2. Press  to turn the backlight off or on.

### **View Real Time Clock**

To view the time function during normal measurement (not during datalogging):

1. Press **TIME**. The time information (hour, minute, second) will appear on the lower display of the LCD.

### **View Sampling Time**

To view the sampling time function during normal measurement (not during datalogging):

1. Press **SAMPLING CHECK**. The sampling time (in seconds) will appear on the lower display of the LCD.

## DATALOGGING

### Preparing the Datalogger

1. Insert the SD card into the SD card socket on the bottom of the meter, ensuring that the front of the SD card faces the back of the meter.
2. Format the SD card as needed (see page 21).
3. Set the clock if using the meter for the first time (see page 9).
4. Set the decimal type if using the meter for the first time (see page 11).

### Auto Datalogging

1. Set the sampling time to  $\geq 1$  second. Refer to page 10.
2. Press **REC**. “REC will appear on the LCD.
3. Press **LOGGER**. “DATALOGGER” will flash on the LCD and the alarm will sound while the measurement data and time information are saved to memory.
4. To pause datalogging, press **LOGGER**. The meter will temporarily stop recording and “DATALOGGER” will stop flashing on the LCD. Press **LOGGER** again to resume datalogging. “DATALOGGER” will flash on the LCD.
5. To finish datalogging, pause the datalogger. Press **REC** for 2 seconds or longer. “REC” will disappear from the LCD to indicate that datalogging has ended.

### Note...

To enable/disable the touch-tone feature, see page 10.

## Manual Datalogging

1. Set the sampling time to 0 seconds. Refer to page 15.
2. Press **REC**. “REC” will appear on the LCD.
3. Press **LOGGER**. “DATALOGGER” will flash on the LCD and the alarm will sound while the measurement data and time information are saved to memory. The position (location) number will appear on the bottom of the LCD and will also be recorded on the SD card.

### Note...

To enable/disable the touch-tone feature, see page 10. Press ▲ or ▼ to set the position number (from 1 to 99). To indicate the position location, P x (x = 1 to 99) will appear on the lower display.

4. To finish datalogging, press **REC** for longer than 2 seconds. “REC” will disappear from the LCD to indicate that datalogging has ended.

## SD Card Data Structure

1. The first time a SD card is used in this meter, a folder PHA01 will be generated.
2. If the datalogger is being used for the first time, a new file PHA01001.XLS will be generated under the route PHA01\ . After exiting the datalogger and executing the function again, the data is saved to the PHA01001.XLS file until the data reach 30,000 data columns. A new file will then be generated (i.e., PHA01002.XLS).

3. The folder PHA01\ will hold 99 files. A new route (i.e., PHA02\ ) will be generated when exceeding 99 files.

4. The file's route structure:

PHA01\

PHA01001.XLS

PHA01002.XLS

PHA01099.XLS

PHA02\

PHA02001.XLS

PHA02002.XLS

PHA02099.XLS

PHAXX\

**Note...**

XX: Maximum value is 10.

## BATTERY REPLACEMENT

This meter uses six AA (1.5 V, UM3) batteries. When the low battery indicator icon appears on the LCD, battery replacement is needed. After the icon appears on the LCD, in-spec measurement can still be made for several hours before becoming inaccurate.

1. Press and hold **POWER** for 2 seconds to turn the meter **o**□.
2. Unscrew the battery cover and remove from the meter.
3. Remove the old batteries and replace with six new AA batteries, ensuring correct polarity.
4. Replace the battery cover. Tighten the screws on the battery cover to secure to the meter.

## MAINTENANCE

### pH Probe

It is important to keep the pH probe wet when not in use. The probe is protected by a plastic bottle containing solution. To use or store the probe:

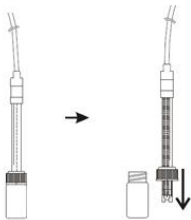

1. Rotate the bottle to remove the bottle from the probe. Pull down the cover and remove it from the probe.
2. After use, put the cover back on the probe and plug the probe into the bottle. Rotate the bottle to fit into the cover tightly.

The following actions will keep the probe in good working condition:

- Always keep the pH glass bulb wet by using the plastic bottle to protect and store the probe. You can also store it in a KCl solution. Never use distilled or de-ionized water for storage
- Always rinse the pH probe in de-ionized water before using
- Never touch or rub the glass bulb tip.

### ORP Probe

Before using, remove the soaking bottle, soak the probe in distilled water, and rinse. Gently dry the sensing element.



## **ORP Probe Cleaning**

A contaminated sensing element can result in a slow response and/or inaccurate reading.

- If the contamination is mineral matter, put the sensing element in a 0.1 N HCl solution for 10 minutes. Rinse in distilled water.
- If the contamination is oil or grease, clean with a mild detergent. Rinse in distilled water.

Upon completion of either cleaning method, immerse the probe in a saturated buffer solution with pH 4.01 for 15 minutes and rinse with distilled water. After cleaning, soak the probe in solution for at least 8 hours.

## **Probe Performance**

The sensing element of an ORP probe is made of a high purity metal. Soaking the sensing element in a solution for a long period of time may cause slow response time and inaccurate readings. An oxidation reduction coating may have formed on the surface of the sensing element. Resolve by cleaning the element.

When measuring a solution with a low concentration of oxidation reduction matter and slow ion exchange rate, a slow response time and inaccurate readings may occur. Under these conditions, it may take 8-24 hours to obtain an accurate reading.

## TROUBLESHOOTING

### System Reset

If the meter is not functioning properly (i.e., the system is frozen and the keypad is non-operational), reset the meter:

1. Press **POWER** to turn the meter **on**.
2. Use a small tool (such as a disassembled paperclip or a pin) to press the **RESET** button (located on the right side of the meter under the protective black cover). Wait a few seconds for the meter to restart.

## **OPTIONAL ACCESSORIES**

- SP-840016** pH Probe (non-ATC)
- SP-840038** ATC Temperature Probe
- SP-840049** Spear Tip pH Probe (non-ATC)
- SP-840051** Flat Surface pH Probe
- SP-850088** ORP Probe
- SP-840058** USB Power Cable
- SP-840097** AC Adaptor
- SP-840059** 2GB SD Card
- SP-840090** Water Resistant Instrument Pouch
- SP-840093** Field Tripod
- SP-860008** pH4, 3 bottles, 40mL each
- SP-860009** pH7, 3 bottles, 40mL each
- SP-860010** pH10, 3 bottles, 40mL each
- SP-860011** De-ionized Water, 3 bottles, 40mL each

## SPECIFICATIONS

### General

<b>Circuit</b>	Custom one-chip of microprocessor LSI circuit
<b>Display</b>	LCD size: 52 mm x 38 mm Backlight function
<b>Measurement Unit</b>	pH ORP (mV)
<b>Sampling Time of Display</b>	Approximately 1 second
<b>Memory Card</b>	SD card 1 GB to 16 GB
<b>Operating Temperature</b>	0 - 50°C
<b>Operating Humidity</b>	< 85%RH
<b>Power Supply</b>	Alkaline or heavy duty DC 1.5 V battery (UM3, AA) x 6 pieces
	DC 9V adapter input (AC/DC power adapter is optional)

<b>Power Current</b>	Normal Operation (without use of the datalogger or backlight): Approximately DC 14 mA
	Datalogger Operation (backlight is off): Approximately DC 37 mA
	If the backlight is on, the power consumption will increase by approximately 12 mA.
<b>Dimensions</b>	177 x 68 x 45 mm 7 x 2 ¾ x 2"
<b>Weight</b>	489 g (1 lb)

The following specifications tests were performed in an ambient temperature of  $23 \pm 5^{\circ}\text{C}$ :

<b>pH Probe</b>	Optional, Any pH probe with BNC Connector	
<b>Measurement</b>	pH	0 to 14 pH
	mV	-1999 to 1999 mV
<b>Input Impedance</b>	$10^{12}$ ohm	

<b>Temperature Compensation for pH Measurement</b>	Manual	0 to 100°C adjustable in Setup Mode
	Automatic (ATC)	0 to 65°C (with included ATC Probe - Model
<b>pH Calibration</b>	pH 7, pH 4, and pH 10, 3 point calibration ensures the best linearity and accuracy	

<b>Unit</b>	<b>Range</b>	<b>Resolution</b>	<b>Accuracy</b>
pH	0 to 14 pH	0.01 pH	± (0.02 pH + 2 d)
mV (ORP)	0 to 1999 mV	1 mV	± (0.5% + 2 d)

**Note...**

The pH accuracy applies to a calibrated meter only.



## **WARRANTY**

This warranty does not cover probes, batteries, battery leakage, or damage resulting from accident, tampering, misuse, or abuse of the product. Opening the meter to expose its electronics will void the warranty.

To obtain warranty service, Contact you Distributor:

### **SCIGIENE CORPORATION**

Tel: 416-261-4865

Email: [support@scigiene.com](mailto:support@scigiene.com)

The defective unit must be accompanied by a description of the problem and your return address.



1295 Morningside Ave., Unit 16-18  
Scarborough, ON. M1B 4Z4 Canada  
Phone: 416-261-4865 Fax: 416-261-7879